

# Product Specification

**Product Name:** Particulate Matter Sensor

**Product Model** PMS9103M

**Specification No.:** PTQ3064-2020

**Version:** V1.4

Writer	Verifier	Standardization	Approver
Zhao Zhendong	Zheng Haoxin	Lu Lili	Zhou Yong
2021-12-31	2021-12-31	2021-12-31	2021-12-31

ADD: No.3 Workshop of Yubo Science and Technology Park, Nanchang Economic and Technological Development Zone, Nanchang City, Jiangxi Province

TEL: 010-64731933

FAX: 010-64737980

URL: [www.plantower.com](http://www.plantower.com)

Email: [info@plantower.com](mailto:info@plantower.com)



➤ **Main Characteristics**

- ◆ Laser scattering principle Correct data
- ◆ Zero false alarm rate
- ◆ Real-time response
- ◆ Minimum distinguishable particle diameter :0.3 micrometer
- ◆ High anti-interference performance because of the structure of six sides shielding

➤ **Overview**

PMS9103M is a kind of digital and universal particle concentration sensor, which can be used to obtain the number of suspended particles in the air, i.e. the concentration of particles, and output them in the form of digital interface. This sensor can be inserted into variable instruments related to the concentration of suspended particles in the air or other environmental improvement equipments to provide correct concentration data in time.

➤ **Working principle**

Laser scattering principle is used for such sensor, i.e. produce scattering by using laser to radiate suspending particles in the air, then collect scattering light in a certain degree, and finally obtain the curve of scattering light change with time. In the end, equivalent particle diameter and the number of particles with different diameter per unit volume can be calculated by microprocessor based on MIE theory. Please find the functional diagram of each part of sensor from Figure 1 as follows.

**Technical Index**

Table 1 PMS9103M Technical Parameters

Parameter	Index
Particle Range of measurement	0.3~1.0μm; 1.0~2.5μm; 2.5~10μm
Particle Counting Efficiency	50%@0.3μm 98%@≥0.5μm
Particle Effective Range (PM2.5 standard)	0~500μg/m <sup>3</sup>
Particle Maximum Range (PM2.5 standard) *	≥1000μg/m <sup>3</sup>
Particle Resolution	1μg/m <sup>3</sup>
Particle Maximum Consistency Error (PM2.5 standard data)*	±10%@100~500μg/m <sup>3</sup> ±10μg/m <sup>3</sup> @0~100μg/m <sup>3</sup>
Particle Standard Volume	0.1L
Single Response Time	<1s
Total Response Time	≤10s
DC Power Supply	Typ: 5.0V Min:4.5V Max:5.5V
Ripple Wave	≤200mV
Active Current	≤100mA
Standby Current	≤2mA
Interface Level	L<0.8V @3.3V H>2.7V @3.3V
Working Temperature Range	-10 ~ +60°C
Working Humidity Range	0~95%(No condensation)
Storage Temperature Range	-20 ~ +80°C
MTTF	≥5 Years
Physical Size	48mm×40mm×12mm

❖ Maximum range means that the highest output value of the PM2.5 standard data is not less than 1000.

❖ “PM2.5 standard data” is the “data2” in the appendix A.20°C,50%.

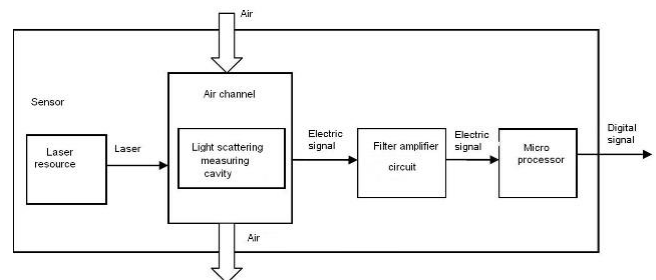

Figure 1 Functional block diagram of sensor

## PIN Definition and Typical Circuit

### ➤ PIN Definition

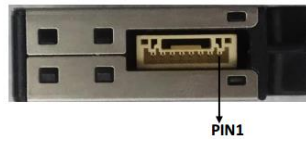

Figure 2 Connector Definition

Table 2 Digital interface pin definition

PIN	Function	Description
PIN1	VCC	Positive power 5V
PIN2	GND	Negative power
PIN3	SET	Set pin/TTL level @3.3V, high level or suspending is normal working status, while low level is sleeping mode.
PIN4	RXD	Serial port receiving pin/TTL level@3.3V
PIN5	TXD	Serial port transmission pin /TTL level@3.3V
PIN6	RESET	Module reset signal/TTL level@3.3V, low reset
PIN7	NC	Not connected
PIN8	NC	Not connected

### ➤ Typical Circuit

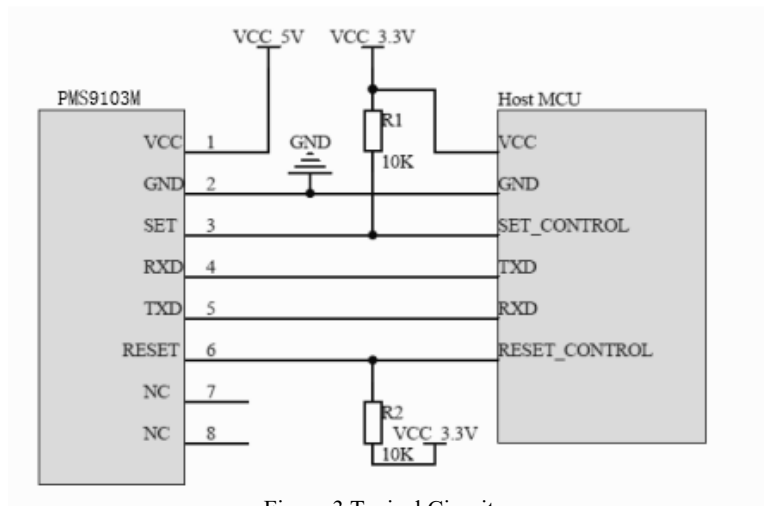

Figure 3 Typical Circuit

#### ❖ Circuit Attentions

- 1) DC 5V power supply is needed because the FAN should be driven by 5V. But the high level of data pin is 3.3V. Level conversion unit should be used if the power of host MCU is 5V.
- 2) The SET and RESET pins are pulled up inside so they should not be connected if without usage.
- 3) PIN7 and PIN8 should not be connected.
- 4) Stable data should be got at least 30 seconds after the sensor wakeup from the sleep mode because of the fan's performance.

## Output Result and Typical Characteristics

### ➤ Output Result

Mainly output as the quality and number of each particles with different size per unit volume, the unit volume of particle number is 0.1L and the unit of mass concentration is  $\mu\text{g}/\text{m}^3$ .

There are two options for digital output: passive and active. Default mode is active after power up. In this mode sensor would send serial data to the host automatically. The active mode is divided into two sub-modes: stable mode and fast mode. If the concentration change is small the sensor would run at stable mode with the real interval of 2.3s. And if the change is big the sensor would be changed to fast mode automatically with the interval of 200~800ms, the higher of the concentration, the shorter of the interval.

### ➤ Typical Output Characteristic

PM2.5 Concentration (Data 2 in Appendix A)

- ❖ Definition of axis Y: unit  $\mu\text{g}/\text{m}^3$
- ❖ Definition of axis X: unit times

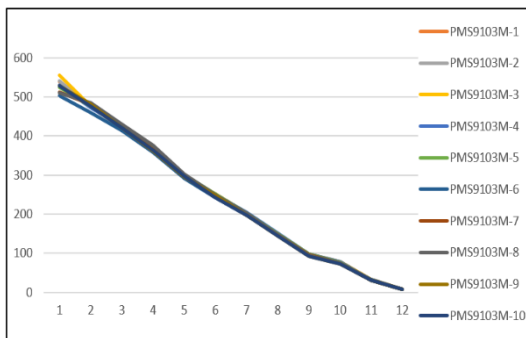

Figure 4-1 Consistency at 20°C

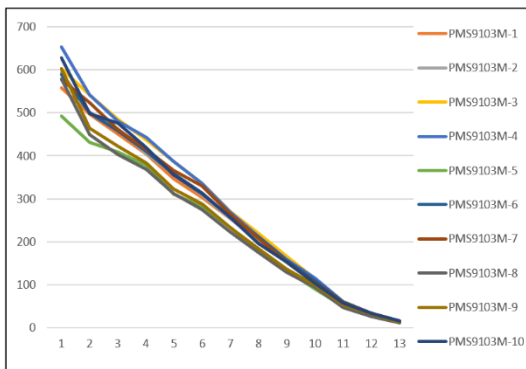

Figure 4-2 Consistency at 43°C

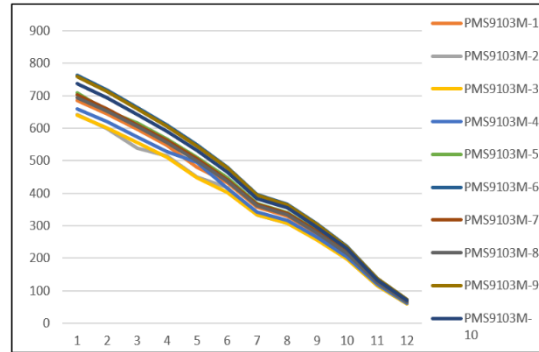

Figure 4-3 Consistency at -5°C

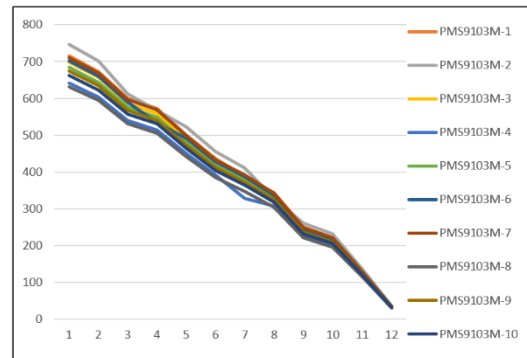

Figure 4-4 Consistency after 30 days running

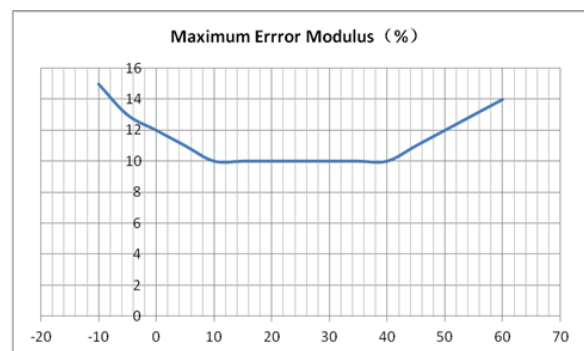

Figure 4-5 Consistency Vs Temperature

Reliability Characteristics

No.	Item	Test Method	Characteristics	Sample No.: N Defective: C
1	Long Running	30 m <sup>3</sup> closed Lab, 20~30°C, humidity 30%~70%, particle generator and air cleaner Check consistency after 720 hours' running	10 samples during 0~500µg/m <sup>3</sup>  1) 0~100µg/m <sup>3</sup> Maximum Error≤±10µg/m <sup>3</sup>  2) 100~500µ g/m <sup>3</sup> Maximum Error≤±10%; 3) FAN does not screeched	N=10, C=0
2	Vibration	1. DC 5V power supply and check consistency 2. Frequency: 50Hz。 3. acceleration: 9.8/ S <sup>2</sup> 。 4. Direction: X、 Y、 Z 5. Vibration Amplitude: ±2mm。 6. Time: X、 Y、 Z -way, Per 1 hour		N=5, C=0
3	High Temperature Operation	At 70°C, the sensor works continuously for 72 hours, and then returns to the normal temperature 25±5°C for 2 hours		N=10, C=0
4	Low Temperature Operation	At -10°C, the sensor works continuously for 72 hours, and then returns to the normal temperature 25±5°C for 2 hours		N=10, C=0
5	High Concentration Environmental Test	In the 3m <sup>3</sup> closed laboratory chamber, PM2.5 concentration remained stable above 1000ug, and the consistency was detected after the sensor was placed in the laboratory chamber for 240 hours		N=10, C=0
6	High Temperature and Humidity Storage	60°C±2°C, humidity 90%~95% , storage 48 hours, Check consistency after 2 hours' room temperature 25±5°C storage		N=10, C=0
7	Low Temperature Storage	-20°C±2°C, storage 72 hours, Check consistency after 2 hours room temperature 25±5°C storage		N=10, C=0
8	Variation of Power Supply	30m <sup>3</sup> closed Lab, 20~30°C, humidity 40%~60%, particle generator and air cleaner  Power varies as the cycles of 4.5V to 5.5V , then 5.5V to 4.5V with the pace of 0.1V/min for 2 hours. Check consistency during Variation		N=5, C=0
9	Power On-Off Cycle	DC 5V power supply, keep On-Off frequency 0.5Hz for 72 hours and check consistency		N=10, C=0
10	Laser On-Off Cycle	keep laser On-Off frequency 100Hz for 240 hours and check consistency		Laser and sensor work normally.  N=10, C=0
11	Salt Spray	(5±1) % industrial salt water, the pH value was 6.5-7.2, The salt spray settlement is 1-2ml (collected by 80cm square funnel), at (35±2)°C continuous spray for 24h and then washed with pure water and blown away the water droplets , placed at room temperature for 1h for inspection and determination .		No red rust, white spots, rust spots and other corrosion area is less than 0.5%.  N=2, C=0
12	Shell Shielding	Switch the multimeter to the resistance, and the two meter tips are placed on the shielding housing on both sides of the sensor		The shielding shells on both sides shall be connected  N=10, C=0
13	The Zero Test	30m <sup>3</sup> closed Lab, 20~30°C, humidity 40%~60%, air cleaner to 0ug/m <sup>3</sup>  DC 5V power supply and check consistency		PM2.5 value less than 3ug/m <sup>3</sup>  N=10, C=0

Physical Size and Packaging

➤ Part Number Definition

PMS 91 03 M

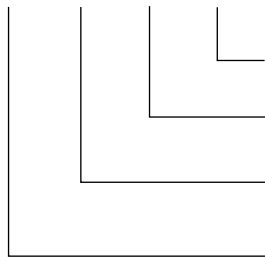

Min distinguishable 0.3 $\mu$ m

Version code

Sensor type: PMS- Particulate Matter Sensor

➤ Sensor label



➤ Physical Size

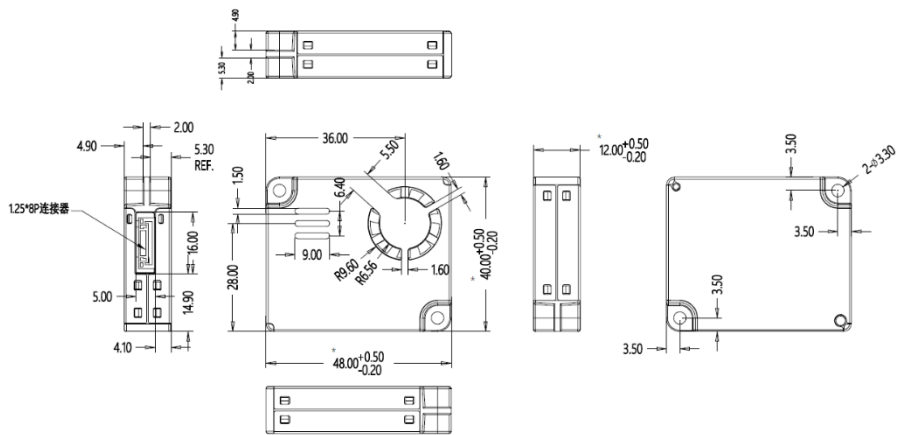
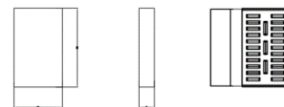
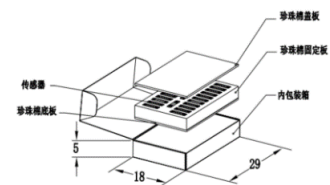
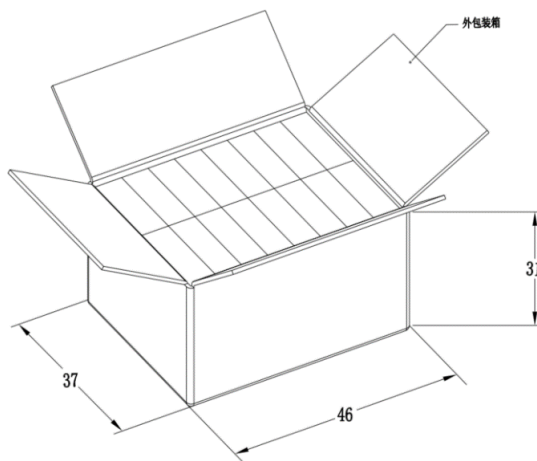

Figure 5 Physical size(Unit:mm)

➤ Packaging Information



说明: 1. 外包装箱每箱最大包装数量: 每箱400PCS  
2. 每个外包装箱最多装16只内包装箱, 每只内包装箱最多装25PCS;

**Attentions**

---

**➤ Installation Attentions**

- a) Metal shell is connected to the GND so be careful not to let it shorted with the other parts of circuit except GND.
- b) The best way of install is making the plane of inlet and outlet closely to the plane of the host. Or some shield should be placed between inlet and outlet in order to prevent the air flow from inner loop.
- c) The blowhole in the shell of the host should not be smaller than the inlet.
- d) The sensor should not be installed in the air flow way of the air cleaner or should be shielded by some structure.
- e) The sensor should be installed at least 20cm higher than the grand in order to prevent it from blocking by the flock dust.
- f) When the sensor is used to outdoor fixed equipment, the equipment should be completed for the protection of sandstorm,rain,snow,etc.
- g) Do not break up the sensor.

**➤ Other Attentions**

- a) Only the consistency of all the PM sensors of PLANTOWER is promised and ensured. And the sensor should not be checked with any third party equipment.
- b) The sensor is usually used in the common indoor environment. So some protection must be added if using in the conditions as followed:
  - i. The time of concentration  $\geq 300\mu\text{g}/\text{m}^3$  is longer than 50% of the whole year or concentration  $\geq 500\mu\text{g}/\text{m}^3$  is longer than 20% of the whole year.
  - ii. Kitchen
  - iii. Water mist condition such as bathroom or hot spring.
  - iv. Outdoor

**Appendix A: Active Transport Protocol**

Baud Rate: 9600 bit/s Data Bits:8 Parity:None Stop Bit:1

Total protocol length:32 byte

Definition	Note
Start character 1	0x42
Start character 2	0x4D
Frame length high 8 bits	Frame length=2x13+2(data+check bytes)
Frame length low 8 bits	
Data 1 high 8 bits	Data 1 refers to PM1.0 concentration unit $\mu\text{g}/\text{m}^3$ (CF=1, standard particle) *
Data 1 low 8 bits	
Data 2 high 8 bits	Data 2 refers to PM2.5 concentration unit $\mu\text{g}/\text{m}^3$ (CF=1, standard particle)
Data 2 low 8 bits	
Data 3 high 8 bits	Data 3 refers to PM10 concentration unit $\mu\text{g}/\text{m}^3$ (CF=1, standard particle)
Data 3 low 8 bits	
Data 4 high 8 bits	Data 4 refers to PM1.0 concentration unit $\mu\text{g}/\text{m}^3$ (under atmospheric environment)
Data 4 low 8 bits	
Data 5 high 8 bits	Data 5 refers to PM2.5 concentration unit $\mu\text{g}/\text{m}^3$ (under atmospheric environment)
Data 5 low 8 bits	
Data 6 high 8 bits	Data 6 refers to PM10 concentration unit $\mu\text{g}/\text{m}^3$ (under atmospheric environment)
Data 6 low 8 bits	
Data 7 high 8 bits	Data 7 indicates the number of particles with diameter beyond 0.3 $\mu\text{m}$ in 0.1 L of air.
Data 7 low 8 bits	
Data 8 high 8 bits	Data 8 indicates the number of particles with diameter beyond 0.5 $\mu\text{m}$ in 0.1 L of air.
Data 8 low 8 bits	
Data 9 high 8 bits	Data 9 indicates the number of particles with diameter beyond 1.0 $\mu\text{m}$ in 0.1 L of air.
Data 9 low 8 bits	
Data 10 high 8 bits	Data 10 indicates the number of particles with diameter beyond 2.5 $\mu\text{m}$ in 0.1 L of air.
Data 10 low 8 bits	
Data 11 high 8 bits	Data 11 indicates the number of particles with diameter beyond 5 $\mu\text{m}$ in 0.1 L of air.
Data 11 low 8 bits	
Data 12 high 8 bits	Data 12 indicates the number of particles with diameter beyond 10 $\mu\text{m}$ in 0.1 L of air.
Data 12 low 8 bits	
Data 13 high 8 bits	Version
Data 13 low 8 bits	Error code
Data and check high 8 bits	Check code=Start character 1+ Start character 2+.....+data 13 low 8 bits
Data and check low 8 bits	

❖ Note1: CF=1 should be used in the factory environment

**Appendix B: Passive Transport Protocol**

Baud Rate: 9600 bit/s Data Bits:8 Parity:None Stop Bit:1

1. Host protocol

Start Byte 1	Start Byte 2	Command	Data 1	Data 2	Verify Byte 1	Verify Byte 2
0x42	0x4D	CMD	DATAH	DATAL	LRCH	LRCL

2. Command Definition

CMD	DATAH	DATAL	Note
0xE2	X	X	Read in passive mode
0xE1	X	00H-Passive,01H-Active	Change mode
0xE4	X	00H-Sleep,01H-Wakeup	Sleep set

3. Answer

a) 0xE2: 32bytes , same as appendix A

b) 0xE1:

Start Byte 1	Start Byte 2	Frame length1	Frame length2	Command	Data	Verify Byte 1	Verify Byte 2
0x42	0x4D	0x00	0x04	0xE1	Work mode	LRCH	LRCL

c) 0xE4:

Start Byte 1	Start Byte 2	Frame length1	Frame length2	Command	Data	Verify Byte 1	Verify Byte 2
0x42	0x4D	0x00	0x04	0xE4	Sleep /wakeup	LRCH	LRCL

4. Verify Bytes:

Add of all the bytes except verify bytes.

